

REV.	Description	Engineer	Date

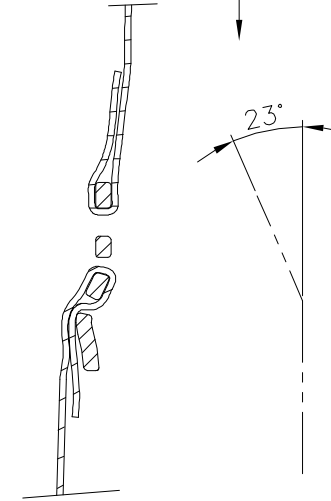
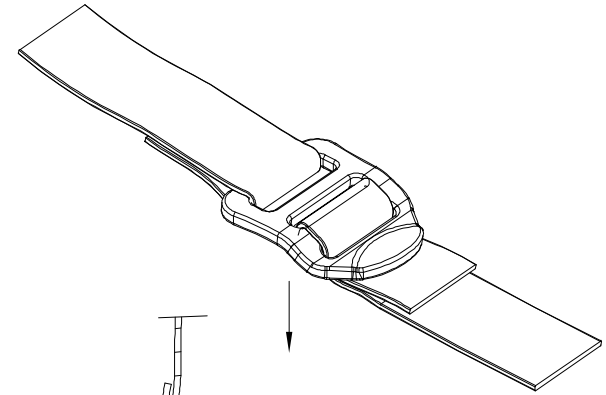
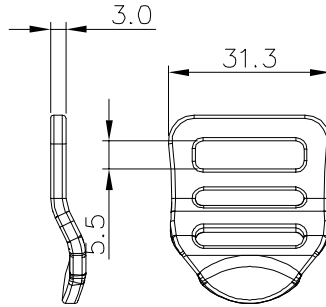
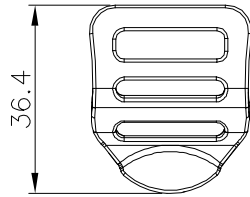
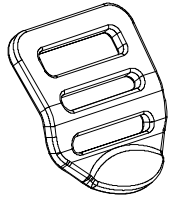

Clearance angle at webbing open
(SECTION HOOK AND WEBBING)

- NOTES -

1. Material : ALU6061-T6 T=3MM
2. Burr of bracket should be minimized(0.03mm)and bracket should be free of sharp edge.
3. Unspecified radius of bracket should be 0.7mm.
5. ** marked dimensions are important, need careful management.
6. Sample approval is required before manufacturing.
7. Confer with the person in chrage on the other matters.

GENERAL TOLERANCE	STEP (mm)	Level 1	Level 2	Level 3	Date :	ITEM NAME: O-RING HOOK
	0-50	±0.1	±0.2	±0.3	Weight : g :	ITEM NO: HK014_ORING_25MM
	51-100	±0.15	±0.3	±0.6	Size :	Material: ALU6061-T6
	101-200	±0.2	±0.4	±0.8	Color :	Approva by :
	201-above	±0.3	±0.6	±1.0	Scale :	Draw by :
0-180°	±3°	±5°	±7°	Sheet:		
THESE DRAWINGS AND SPECIFICATIONS ARE THE PROPERTY OF WETOOL AND WEKORE AND SHALL NOT BE REPRODUCED, COPIED OR CUED IN ANY MANNER WITHOUT THE PRIOR WRITTEN CONSENT OF WETOOL AND WEKORE						